

29/16

I- 18/16



পশ্চিমবঙ্গ পশ্চিম বঙ্গাল WEST BENGAL

1145513/16
 06/01/16



Certified that the Document is admitted in
 Registration and the Signature Sheet and
 the Endorsement Sheet attached to this
 Document are part of it. Document

Jai Krishan Chandak
 @ Jay Prakash Chandak

Add. District Sub-Registrar
 Bhakti Nagar, Jalpaiguri

06 JAN 2016

DEED OF GIFT

Contd. /2

R.K. Ag
 Adm 154

N. J. Stamp

Sl. No. 485 Date. 17-12-15
Sold to..... Jai Kishan chandak
@ Jay Kishan chandak
of..... Rangpur, Sikkim
Value... 5000/- Rupees. Five thousand only

J. Sanik

JAYABRATA BANIK
Govt. Stamp Vender
A.D.S.R. Office Bagdogra
L/No- 539-R.M./Darjeeling
Year 2007



Addl. Dist Sub-Registrar
Bhakti Nagar, Dist-Jalpaiguri

06 JAN 2016

Faukishan Chandak
@ Jay keekshan Chandak

THIS DEED OF GIFT IS MADE ON THIS THE
6th DAY OF JANUARY, 2016

Contd. /3

R.M. Ag
Adv/1/16

Jai kishan Chandak
@ Jay, Krishan Chandak

VALUE ASSESSED :- Rs. 46,40,000/-
Area :- 7 Kathas 9 Chhattaks 27 Sq.ft.
Mouza :- Dabgram
Plot No. : 66 (R.S.)
J.L.No. 2
Khatian No. : 757/13 (R.S.)
Sheet No. : 15
P. S. : Bhaktinagar
Dist. : Jalpaiguri
Within Ward No. 32 of S.M.C.

BY

SRI JAI KISHAN CHANDAK @ SRI JAY KRISHAN CHANDAK S/O LATE CHAMPA LAL CHANDAK, Hindu by religion, Advocate by Profession, Indian by Citizenship, residing at House No. 174/13, Lall Bazar, Gangtok, P.O. Gangtok, P.S. Sadar Police Station, Dist. East Sikkim, Sikkim, hereinafter called the **DONOR** (which expression shall mean and include unless excluded by or repugnant to the context his legal heirs, successors, executors, administrators, legal representatives and /or assigns) of the **ONE PART.**

R.K.A.
Advy

Jai Kishan Chandak
 Jay Kishan Chandak

IN FAVOUR OF

SRI INDER KUMAR CHANDAK (Having PAN No. AEXPC3878H) S/O LATE CHAMPA LAL CHANDAK,
 Hindu by religion, Business by occupation, Indian by Citizenship, residing at New Milanpally, P.O. & P.S. Siliguri-734005, Dist. Darjeeling, hereinafter called the **DONEE** (which expression shall mean and include unless excluded by or repugnant to the context his legal heirs, successors, executors, administrators, legal representatives and /or assigns) of the **OTHER PART.**

WHEREAS the Donor hereof, is the sole and absolute owner in possession of vacant land measuring **7 Kathas 9 Chhattaks 27 Sq.ft.**; appertaining to and forming part of **Plot No. 66 (R.S.) 57 (L.R.)**, recorded in Khatian No.757/13 (R.S.), situated within **Mouza - Dabgram**, Pargana - Baikunthapur, J.L. No. 2, **Sheet No. 15 (R.S.)**, P.S. Bhaktinagar, Dist. Jalpaiguri, by virtue of registered Deed of Sale being No. **(1196)** dated **27/03/2000**, recorded in **Book No. 1, Volume No. 14, Pages 263 to 268**, for the year 2000, registered in the office of the **Sub-Registrar, Rajganj**, Dist. Jalpaiguri, executed by Sri **Manoj Kumar Jajodia S/o Sri Shawal Ram Jajodia** of **Khalpara**, P.O. & P.S. Siliguri, Dist. Darjeeling, morefully and particularly described in **Schedule**, having permanent, heritable and transferrable right; title and interest therein, free from all encumbrances whatsoever.

R. K. Ag
 Adv / 14

AND

Jai Kishan Chandak
 Jay Kishan Chandak

WHEREAS the Donee is the Brother of Donor and the Donor out of his natural love and affection, is desirous to make absolute gift of his land, as fully described in the "**Schedule**", in the favour of the Donee and the Donee has also agreed to accept the same, free from all encumbrances whatsoever.

NOW THIS INDENTURE WITNESSETH AS UNDER:

1. That in pursuance of the aforesaid desire and decision of the Donor and in consideration of deep love and affection, which the Donor has for the Donee, the Donor out of his free will and without any fear, fraud, coercion, undue influence or pressure from any body whomsoever do hereby give, grant, transfer, convey by way of absolute gift his land, as fully described in the **Schedule** below, in favour of the Donee, freely and voluntarily and without any monetary or other consideration whatsoever **"TO HAVE AND TO HOLD"** the same for his respective sole use and benefit, absolutely and unconditionally forever without any objection, obstruction and hindrance from any other legal heir/s whatsoever he/she may be.
2. That in pursuance of the aforesaid gift, the receipt and acceptance thereof the Donor hereby acknowledge and grant and transfer, assign all rights of possession and enjoyment together with all rights, liberties, privileges,

R.K. Ag
 Adv/CP

Contd. /6

Jai Krishan Chandok
@ Jay Krishan Chandok

6

easement, appurtenances, appendages, whatsoever belonging thereto or in any way appertaining and attached to the said land, as fully described in the "**Schedule**-" below, if any free from all encumbrances and rights, title and interest of the Donor in to or upon the same.

3. The Donor covenants with the Donee that he is the owner of land, as morefully described in the "**Schedule**" below.
4. The Donor hereby covenants with the Donee that the land gifted herein shall be quietly hold and enjoyed and the rents and profits, if any shall be enjoyed by the Donee absolutely.
5. That it is further declared by the Donor that the Donor has not made any will in respect of his land, as fully described in the "**Schedule**" below, in favour of any person/s and there exists no such will etc.
6. That the Donor further declares that from the day of the execution of this Deed of Gift, the Donee will become the absolute owner of the land, as morefully described in the "**Schedule**" below.
7. That the Donor further declares that the Stamp Duty has been paid by the Donor according to the value as assessed by the Registering Authority.

~~R. K. Ag~~
A. K. Ag

Contd. /7

**In The Site Plan Showing The Possession Of Plot To Be Sold Of Mouza - Dabgram
C.I. No. 2, Sheet No. 15, Pargana - Baikunthapur, P.s. - Bhaktinagar, Dist. - Jalpaiguri**

Scale : 16" = 1 Mile

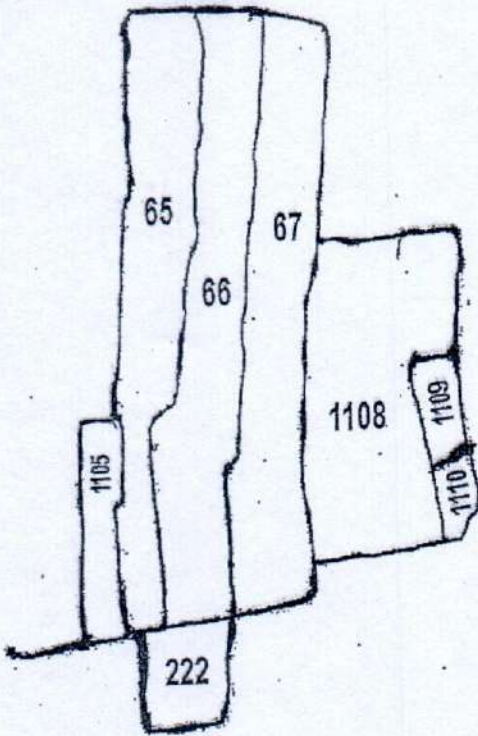

NAME OF THE DONOR

SRI JAI KISHAN CHANDAK
@ SRI JAY KRISHAN CHANDAK
S/O.- SRI CHAMPA LAL CHANDAK
RESIDENT AT.-
HOUSE No. 174/13, LALL BAZAR,
P.O.- GANGTOK, P.S.- SADAR POLICE STATION
DIST.- EAST SIKKIM (SIKKIM)

NAME OF THE DONEE

SRI INDER KUMAR CHANDAK,
S/O.- CHAMPA LAL CHANDAK
RESIDENT AT.- NEW MILLAN PALLY
P.O. & P.S.- SILIGURI - 734005
DIST.- DARJEELING

Area Bounded By :-

N	HOUSE OF SARMILA DUTTA
S	SOLD LAND OF SRI KSHITISH CH. MANDAL
E	17 FEET WIDE ROAD
W	HOUSE OF SRI SAMIRAN GHANDA

KHATIAN NO.	SHEET NO.	PLOT NO.	AREA
757/13	15	66 PART	7 Kathas 09 Chhatak 27 Sq. Ft.

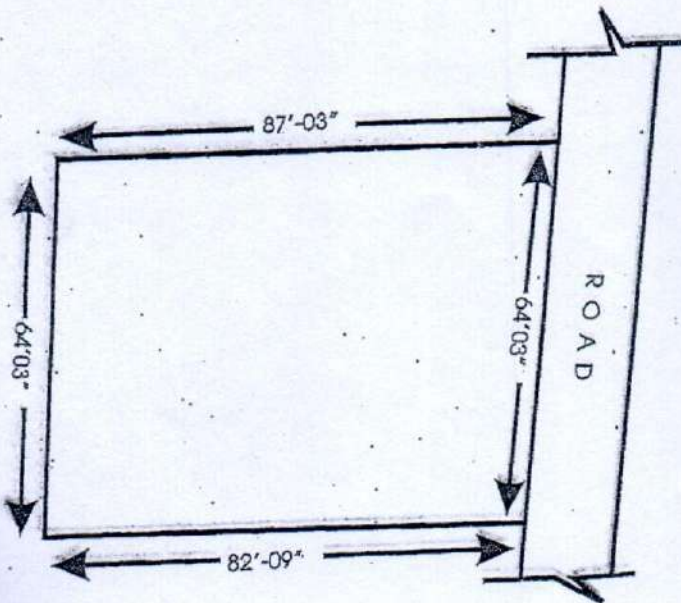

S
I
T
E
P
L
A
N

Jai Kishan Chandak
@ Jay Krishan Chandak

Signature of DONOR

Inder kr. Chandak

Signature of DONEE

7

SCHEDULE

(GIFTED LAND)

Tarakeshan Chandak
B. Jay Keishan Chandak

All that piece or parcel of vacant Bastu land measuring **7 Kathas 9 Chhattaks 27 Sq.ft.**, appertaining to and forming part of **Plot No. 66 (R.S.)**, recorded in **Khatian No.757/13 (R.S.)**, situated within **Mouza - Dabgram**, Pargana - Baikunthapur, J.L. No. 2, **Sheet No. 15 (R.S.)**, P.S. Bhaktinagar, Dist. Jalpaiguri, within Ward No.32 of Siliguri Municipal Corporation.

The said land is butted and bounded as follows :-

North : House of Sarmila Dutta.
South : Sold Land of Sri Kshitish Ch. Mandal.
East : 17 ft. Wide Road.
West : House of Sri Samiran Chanda.

Within the aforesaid butted and bounded. the Donor does hereby gifted his vacant land measuring **7 Kathas 9 Chhattaks 27 Sq.ft.**, to the Donee as shown in the sketch map delineated with Red Ink Border, is forming part of these presents.

R. K. A. G.
Advy/89

Contd. /8

IN WITNESSES WHERE OF THE DONOR AND DONEE HEREOF, in their good health and conscious mind have put their signature on these presents on the day, month and year first above written.

WITNESSES :-

1) *Santosh Malani*
(SRI SANTOSH MALANI)
S/O SRI DWARKA PRASAD MALANI
OF Millanpally, SILIGURI,
P.O. SILIGURI BAZAR-734005,
P.S. SILIGURI,
DIST. DARJEELING,(W.B.)

2) *Manoj Marda*
S/o Subash Chand Marda
Wahro Road
P/O PS Siliguri
DIST DRA

The contents of this document have been gone through and understood personally by the Donor and the Donee.

Jai Krishan Chandak
@ *Jay Krishan Chandak*

SIGNATURE OF THE DONOR

Gift is accepted by me.

Inder kr. Chandak

SIGNATURE OF THE DONEE

Drafted, read and explained to the parties by me and printed in my Office.

Rajesh Kumar Agarwal
(RAJESH KUMAR AGARWAL)
Advocate, Siliguri
Enrolment No. F - 119/384/98.

IMPRESSION SHEET



EXECUTANT

Jai Krishan Chandak
© Jay Krishan Chandak
Jai Krishan Chandak
© Jay Krishan Chandak

	Thumb	Fore Finger.	Middle Finger.	Ring Finger.	Little Finger.
Right left Hand					
Left Right Hand					

Jai Krishan Chandak
© Jay Krishan Chandak
Signature of presentant with date

Signature of Identifier

Signature of R. O.

IMPRESSION SHEET



CLAIMANT SHEET

Inder kv. Chandak

	Thumb	Fore Finger.	Middle Finger.	Ring Finger.	Little Finger.
Left Hand					
Right Hand					

Inder kv. Chandak

Signature of presentant with date

Signature of Identifier

Signature of R. O.

**In The Site Plan Showing The Possession Of Plot To Be Sold Of Mouza - Dabgram
J.I. No. 2, Sheet No. 15, Pargana - Baikunthapur, P.s.- Bhaktinagar, Dist.- Jalpaiguri**

Scale : 16" = 1 Mile

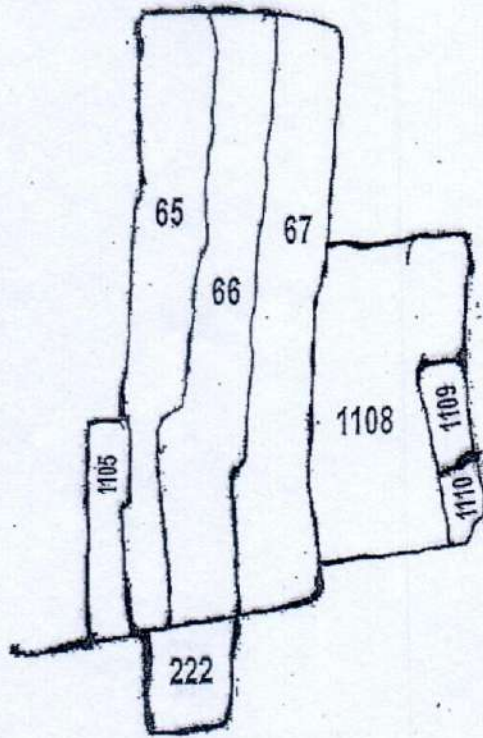

NAME OF THE DONOR

SRI JAI KISHAN CHANDAK
@ SRI JAY KRISHAN CHANDAK
S/O.- SRI CHAMPA LAL CHANDAK
RESIDENT AT.-
HOUSE NO. 174/13, LALL BAZAR,
P.O.- GANGTOK, P.S.- SADAR POLICE STATION
DIST.- EAST SIKKIM (SIKKIM)

NAME OF THE DONEE

SRI INDER KUMAR CHANDAK,
S/O.- CHAMPA LAL CHANDAK
RESIDENT AT.- NEW MILLAN PALLY
P.O. & P.S.- SILIGURI - 734005
DIST.- DARJEELING

Area Bounded By :-

N	HOUSE OF SARMILA DUTTA
S	SOLD LAND OF SRI KSHITISH CH. MANDAL
E	17 FEET WIDE ROAD
W	HOUSE OF SRI SAMIRAN CHANDA

KHATIAN NO.	SHEET NO.	PLOT NO.	AREA
757/13	15	66 PART	7 Kathas 09 Chhatak 27 Sq. Ft.

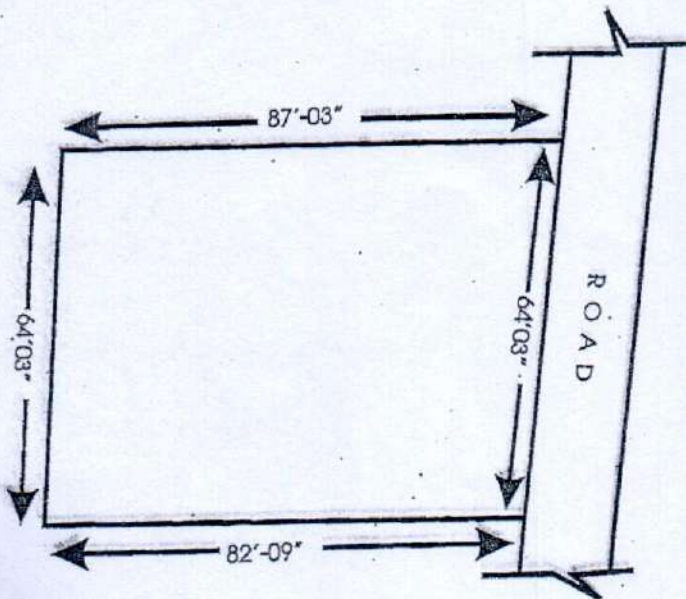

S
I
T
E
P
L
A
N

Jai kishan Chandak
C. Jay Krishan Chandak

Signature of DONOR



Inder k. Chandak



Signature of DONEE

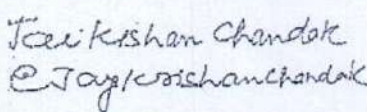

Manoj Kumar
Millan Pally

Seller, Buyer and Property Details

A. Donor & Donee Details

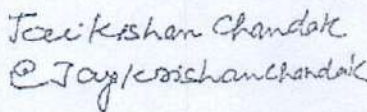
Presentant Details			
SL No.	Name, Address, Photo, Finger print and Signature of Presentant		
1	Shri Jay Krishan Chandak (Alias Name: Shri Jai Kishan Chandak) Son of Late Champa Lal Chandak House No. 174/13, Lall Bazar, Gangtok, P.O:- Gangtok, P.S:- GANGTOK, District:-East, Sikkim, India, PIN - 737101	 06/01/2016 12:33:48 PM	 LTI 06/01/2016 12:34:01 PM
		 06/01/2016 12:34:41 PM	

Donor Details			
SL No.	Name, Address, Photo, Finger print and Signature		
1	Shri Jay Krishan Chandak (Alias: Shri Jai Kishan Chandak) Son of Late Champa Lal Chandak House No. 174/13, Lall Bazar, Gangtok, P.O:- Gangtok, P.S:- GANGTOK, District:-East, Sikkim, India, PIN - 737101 Sex: Male, By Caste: Hindu, Occupation: Advocate, Citizen of: India,; Status : Individual; Date of Execution : 06/01/2016; Date of Admission : 06/01/2016; Place of Admission of Execution : Office	 06/01/2016 12:33:48 PM	 LTI 06/01/2016 12:34:01 PM
		 06/01/2016 12:34:41 PM	

Donee Details			
SL No.	Name, Address, Photo, Finger print and Signature		
1	<p>Shri Inder Kumar Chandak Son of Late Champa Lal Chandak Milanpally, P.O:- Siliguri, P.S:- Siliguri, Siliguri Mc, District:-Darjeeling, West Bengal, India, PIN - 734005 Sex: Male, By Caste: Hindu, Occupation: Business, Citizen of: India, PAN No. AEXPC3878H,; Status : Individual; Date of Execution : 06/01/2016; Date of Admision : 06/01/2016; Place of Admision of Execution : Office</p>	 06/01/2016 12:34:55 PM	 LTI 06/01/2016 12:35:04 PM
		<p style="text-align: center;"><i>Inder kv. Chandak</i></p> 06/01/2016 12:35:22 PM	

B. Identifire Details

Identifier Details			
SL No.	Identifier Name & Address	Identifier of	Signature
1	<p>Shri Santosh Malani Son of Shri Dwarka Prasad Malani Milanpally, P.O:- Siliguri, P.S:- Siliguri, Siliguri Mc, District:-Darjeeling, West Bengal, India, PIN - 734005 Sex: Male, By Caste: Hindu, Occupation: Business, Citizen of: India,</p>	<p>Shri Jay Krishan Chandak, Shri Inder Kumar Chandak</p>	<p><i>Santosh Malani</i></p> 06/01/2016 12:35:47 PM

C. Transacted Property Details

Land Details						
Sch No.	Property Location	Plot No & Khatian No/ Road Zone	Area of Land	Setforth Value(In Rs.)	Market Value(In Rs.)	Other Details
L1	<p>District: Jalpaiguri, P.S:- Bhaktinagar, Municipality: SILIGURI MC, Mouza: Dabgram Sheet No - 15</p>	<p>LR Plot No:- 57(Correspon ding RS Plot No:- 66) , LR Khatian No:- 757/13</p>	<p>7 Katha 9 Chatak 27 Sq Ft</p>	46,40,000/-	46,40,000/-	<p>Proposed Use: Bastu, ROR: Bastu, Property is on Road Adjacent to Metal Road,</p>

D. Applicant Details

Details of the applicant who has submitted the requisition form

Details of the applicant who has submitted the requisition form

Applicant's Name	Rajesh Kumar Agarwal
Address	Nehru Road, Khalpara, Thana : Siliguri, District : Darjeeling, WEST BENGAL, PIN - 734005
Applicant's Status	Advocate

Office of the A.D.S.R. BHAKTINAGAR, District: Jalpaiguri

Endorsement For Deed Number : I - 071100018 / 2016

Query No/Year	07110001145513/2015	Serial no/Year	0711000019 / 2016
Deed No/Year	I - 071100018 / 2016		
Transaction	[0201] Gift, Gift in Favour of family members		
Name of Presentant	Shri Jay Krishan Chandak	Presented At	Office
Date of Execution	06-01-2016	Date of Presentation	06-01-2016

Remarks

On 28/12/2015

Certificate of Market Value (WB P.U.V.I. rules of 2001)

Certified that the market value of this property which is the subject matter of the deed has been assessed at Rs 46,40,000/-. Other amount Rs 46,40,000/-

(Jiban Krishna Das)

ADDITIONAL DISTRICT SUB-REGISTRAR
OFFICE OF THE A.D.S.R. BHAKTINAGAR
Jalpaiguri, West Bengal

On 06/01/2016

Certificate of Admissibility (Rule 43, W.B. Registration Rules 1962)

Admissible under rule 21 of West Bengal Registration Rule, 1962 duly stamped under schedule 1A, Article number : 33(I) of Indian Stamp Act 1899.

Presentation (Under Section 52 & Rule 22A(3) 46(1), W.B. Registration Rules, 1962)

Presented for registration at 12:03 hrs on : 06/01/2016, at the Office of the A.D.S.R. BHAKTINAGAR by Shri Jay Krishan Chandak Alias Shri Jai Kishan Chandak, Executant.

Admission of Execution (Under Section 58, W.B. Registration Rules, 1962)

Execution is admitted on 06/01/2016 by

Shri Jay Krishan Chandak, Alias Shri Jai Kishan Chandak, Son of Late Champa Lal Chandak, House No. 174/13, Lall Bazar, Gangtok, P.O: Gangtok, Thana: GANGTOK, , East, SIKKIM, India, PIN - 737101, By caste Hindu, By Profession Advocate

Identified by Shri Santosh Malani, Son of Shri Dwarka Prasad Malani, Milanpally, P.O: Siliguri, Thana: Siliguri, , City/Town: SILIGURI MC, Darjeeling, WEST BENGAL, India, PIN - 734005, By caste Hindu, By Profession Business

Admission of Execution (Under Section 58, W.B. Registration Rules, 1962)

Execution is admitted on 06/01/2016 by

Shri Inder Kumar Chandak, Son of Late Champa Lal Chandak, Milanpally, P.O: Siliguri, Thana: Siliguri, , City/Town: SILIGURI MC, Darjeeling, WEST BENGAL, India, PIN - 734005, By caste Hindu, By Profession

Business

Identified by Shri Santosh Malani, Son of Shri Dwarka Prasad Malani, Milanpally, P.O: Siliguri, Thana: Siliguri, ,
City/Town: SILIGURI MC, Darjeeling, WEST BENGAL, India, PIN - 734005, By caste Hindu, By Profession
Business

Payment of Fees

Certified that required Registration Fees payable for this document is Rs 51,029/- (A(1) = Rs 51,029/-) and
Registration Fees paid by Cash Rs 0/-, by Draft Rs 51,029/-

Description of Draft

1. Rs 1,975/- is paid, by the Draft(other) No: 319310000405, Date: 22/12/2015, Bank: STATE BANK OF INDIA (SBI), SILIGURI.
2. Rs 41,000/- is paid, by the Draft(other) No: 319090000405, Date: 14/12/2015, Bank: STATE BANK OF INDIA (SBI), SILIGURI.
3. Rs 8,054/- is paid, by the Draft(other) No: 319362000405, Date: 24/12/2015, Bank: STATE BANK OF INDIA (SBI), SILIGURI.

Payment of Stamp Duty

Certified that required Stamp Duty payable for this document is Rs. 23,200/- and Stamp Duty paid by Draft Rs 18,220/-, by Stamp Rs 5,000/-

Description of Stamp

1. Rs 5,000/- is paid on Impressed type of Stamp, Serial no 485, Purchased on 17/12/2015, Vendor named Jaybrata Banik.

Description of Draft

1. Rs 18,220/- is paid, by the Draft(other) No: 319361000405, Date: 24/12/2015, Bank: STATE BANK OF INDIA (SBI), SILIGURI.

(Jiban Krishna Das)

ADDITIONAL DISTRICT SUB-REGISTRAR
OFFICE OF THE A.D.S.R. BHAKTINAGAR
Jaipalguri, West Bengal

Certificate of Registration under section 60 and Rule 69.

Registered in Book - I

Volume number 0711-2016, Page from 2209 to 2226

being No 071100018 for the year 2016.



Digitally signed by JIBAN KRISHNA DAS
Date: 2016.01.06 18:20:15 +05:30
Reason: Digital Signing of Deed.

(Jiban Krishna Das) 06-01-2016 18:20:14
ADDITIONAL DISTRICT SUB-REGISTRAR
OFFICE OF THE A.D.S.R. BHAKTINAGAR
West Bengal.

(This document is digitally signed.)

**in The Site Plan Showing The Possession Of Plot To Be Sold Of Mouza - Dabgram
J.I. No. 2, Sheet No. 15, Pargana - Baikunthapur, P.s.- Bhaktinagar, Dist.- Jalpaiguri**

Scale : 16" = 1 Mile

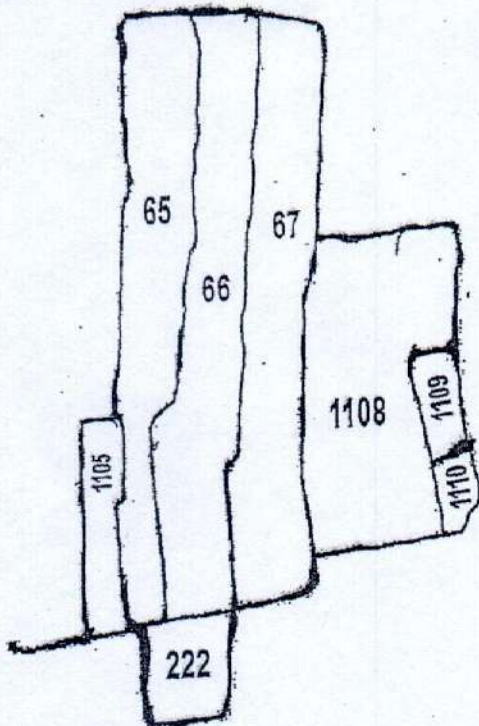

NAME OF THE DONOR

SRI JAI KISHAN CHANDAK
@ SRI JAY KRISHAN CHANDAK
S/O.- SRI CHAMPA LAL CHANDAK
RESIDENT AT.-
HOUSE NO. 174/13, LALL BAZAR,
P.O.- GANGTOK, P.S.- SADAR POLICE STATION
DIST.- EAST SIKKIM (SIKKIM)

NAME OF THE DONEE

SRI INDER KUMAR CHANDAK,
S/O.- CHAMPA LAL CHANDAK
RESIDENT AT.- NEW MILLAN PALLY
P.O. & P.S.- SILIGURI - 734005
DIST.- DARJEELING

Area Bounded By :-

N	HOUSE OF SARMILA DUTTA
S	SOLD LAND OF SRI KSHITISH CH. MANDAL
E	17 FEET WIDE ROAD
W	HOUSE OF SRI SAMIRAN CHANDA

KHATIAN NO.	SHEET NO.	PLOT NO.	AREA
757/13	15	66 PART	7 Kathas 09 Chhatak 27 Sq. Ft.

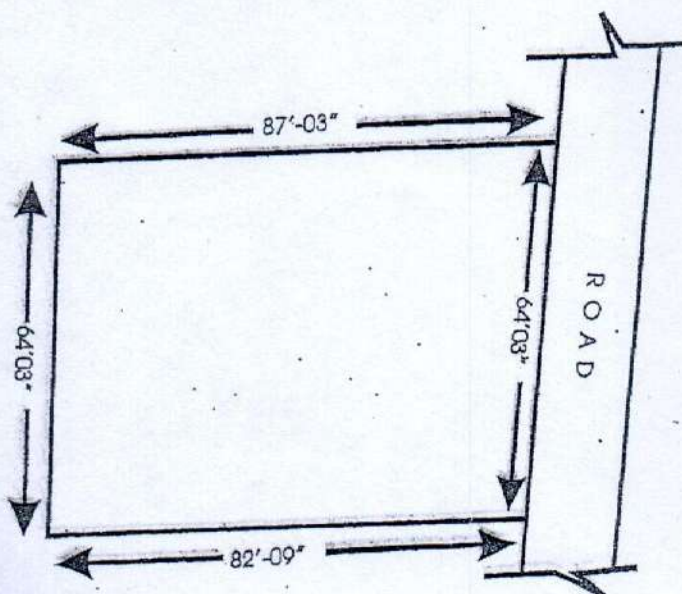

S
I
T
E
P
L
A
N

*Jai kishan Chandak
@ Jay Krishan Chandak*

Signature of DONOR

Inder kv. Chandak

Signature of DONEE